

OPERATION MANUAL

(Including Guidelines for Safe Operation)

HE-2910



INTRODUCTION

Thank you very much for purchasing our product.

- Please be sure to read this manual carefully and understand the contents before the actual operation in order to keep your safety.
- Please store this manual safely at the convenient place so that you can read it when needed.
- Please pass this manual to new owner when you resell or give this unit to someone else.
- We are not responsible for any physical injuries and property damages under product liability (PL) law by wrong usage or any other operations not described in this manual.

DEFINITION OF SYMBOL MARK [CAUTION FOR SAFETY]



DANGER : Incur the accident resulting in the death or serious injuries unless you keep the descriptions.



WARNING : Be in danger of incurring the accident resulting in the death or serious wound unless you keep the descriptions.



CAUTION : Be in danger or incurring the slight wound to human or damage to other physical property unless you keep the descriptions.

- Do not reproduce a part or all of contents described in this manual.
- Please understand that the unit may differ from the contents described in this manual due to the specification changes etc.
- Please inform us if you see any errors and/or unclear descriptions in this manual.

CONTENTS

CAUTION ON SAFETY (BE SURE TO READ THIS).....	1
1. HANDLING OF MAIN UNIT.....	1
2. HANDLING OF CABLE.....	2
3. HANDLING TRANSDUCER AND WATER TEMP SENSOR.....	3
4. REMOTE.....	3
5. HANDLING OF GPS.....	4
6. OPERATION.....	4
7. GPS.....	5
8. CHIRP TECHNOLOGY.....	5
DESCRIPTIONS.....	7
1. FRONT PANEL.....	7
2. REAR VIEW.....	8
HOW TO SEE THE DISPLAY.....	10
HOW TO OPERATE MENU.....	11

BASIC OPERATION

POWER ON/OFF.....	13
INITIAL SET-UP(TD LOCATION SET-UP).....	14
SCREEN BRIGHTNESS.....	14
SIMULATION MODE.....	15
NMEA0183 OUTPUT.....	16
SCREEN CAPTURE TO USB DEVICE.....	17
INITIALIZE.....	17

OPERATION OF ECHO SOUNDER

SOUNDER SCREEN.....	19
DEPTH SET-UP.....	20
WIDE BAND SET-UP.....	20
SENSITIVITY.....	21
EXPANSION MODE.....	23
EXPANSION AREA.....	24
WATER TEMP ALARM.....	25
FISH ALARM.....	25
DEPTH ALARM.....	26
WATER TEMP CORRECTION.....	26
FREQUENCY DISPLAY.....	27
SWEEP SPEED.....	27
SOUNDER SET-UP.....	28
DETAIL SET-UP.....	28
A MODE.....	29
BACKGROUND COLOR.....	29
COLOR CONFIGURATION.....	30
COLOR ERASE.....	30

INTENSE LEVEL	31
CLUTTER	31
DEPTH UNIT	32
SCALE LINE	32
SUPER RANGE	32
WATER TEMP GRAPH	33
AUTO RANGE MAX. DEPTH	33
CLEAN ECHO	33
STC	34
OUTPUT POWER	35
PULSE LENGTH	36
SENSITIVITY MODE	37
SOUNDER DISTANCE SCALE	38
BOTTOM HARDNESS FUNCTION	39
PRESET FUNCTION	39
TRANSDUCER THRU-HULL / IN-HULL SET-UP	40
BROADBAND FREQUENCY TUNING	40
LIST OF ECHO SOUNDER MENU	41

REFERENCE DOCUMENT

DIMENSIONAL DRAWING	45
CONNECTION WITH MAIN UNIT	46
CONNECTOR DIAGRAM	47
GPS ANTENNA MADE BY OTHER COMPANY	47
NMEA CONNECTOR	48
NMEA0183 OUTPUT SENTENCE	48
MAIN UNIT INSTALLATION	49
BUILT-IN INSTALLATION	50
TRANSDUCER INSTALLATION	52
1. INSIDE-HULL	53
2. THRU-HULL	53
WATER TEMP. SENSOR INSTALLATION	54
STANDARD CONFIGURATION	55
OPTIONS	56
THEORY OF ECHO SOUNDER	57
TROUBLE SHOOTING	59
SPECIFICATIONS	62

CAUTION ON SAFETY (BE SURE TO READ THIS)









This explains the important cautions in order to prevent the users and surrounding people from physical injuries and property damages.

1. HANDLING OF MAIN UNIT





DANGER

-  •High voltage is used for the unit inside.
No one besides authorized personnel should disassemble or modify the unit.
If not followed, it may result in electric shock.
※Please be sure to consult with the local dealer for any repairs.

WARNING





-  •Install the unit firmly.
If not, it may cause the accidents such as human injuries.
-  •Do NOT use this unit for navigation purpose.
It may result in the accident.
※Use official paper chart for navigation usage.
-  •Do NOT navigate according to the depth information on the unit.
The depth info on unit may be shown differently compared to the actual depth.
Very shallow water such as 1-2m cannot be detected depending on the conditions.
-  •Do NOT operate the unit while navigating.
It may result in an accident.
-  •Do NOT put the power on in the presence of flammable materials.
It causes the fire.
-  •Do NOT use the power supply besides the specified one.
It causes the firing and heating.
-  •Do NOT disassemble and modify the unit.
It causes the firing, electronic shock, and injury.
-  •Do NOT operate the unit with wet hands.
It causes the electronic shock and damage.
-  •Disconnect the power cable in the case of problem, smoke, and fire.
It causes the firing and electronic shock.
Be sure to contact the local shop or customer support.

CAUTION



-  •Do NOT install the unit where rain or spray dashes hit directly.
It causes the firing and electric shock.
-  •Do NOT install the unit at heated places.
It causes the firing from the increase of internal temperature, injury, and electric shock.
-  •Use the earthing.
Noise influence can be prevented by firm earthing.
-  •Away from direct sun light.
It causes the difficulty of future vision and heat problem.

2. HANDLING OF CABLE

WARNING

-  •Be sure to use the specified power supply cable.
It causes firing and heating.
-  •Do NOT leave the power plug after its removal.
It causes firing and heating if the plug gets wet.
-  •Be sure to wire the cables for safety pilot.
The improper wiring causes the accident.
※Do NOT put the heavy object on cables or bend cables excessively.
-  •Do NOT disassemble or modify the cables.
It causes firing, heating, or electronic shock.
-  •Do NOT use damaged cables.
It causes firing or electric shock.

CAUTION

-  •Do NOT pull out the cable when disconnecting the plug.
The cable damage causes firing and electric shock.
※Be sure to hold and pull the plug itself for the removal.
-  •Do NOT put any pressure on cables when installing the unit.
It causes line cut and shortage.

3. HANDLING TRANSDUCER AND WATER TEMP SENSOR

DANGER



- Any works on the vessel are very unstable and risky.
Installation/Maintenance of transducer and water temp sensor should be handled after landing the vessel on ground or fixing the vessel at shipyard etc.

WARNING



- Be sure to ventilate well inside the vessel when installing the transducer at the bottom of vessel.
Volatile gas from solvent etc causes the toxic symptoms.



- Water proof treatment is required for Thru-Hull installation.
If not, it cause the marine accident.
※It is not allowed for aluminum vessels due to the risk of corrosion.



- Do NOT operate the electronic tools with wet hands.
It cause electric shock.



- Do NOT remove the transducer plug when the power is ON.
It causes electronic shock.

4. REMOTE

DANGER



- Do NOT use any leaked AA-batteries. (for IR usage)
It may cause human injuries if a person touches the leaked liquid.

CAUTION



- Place the remote for safe location when not being used.
Prevent from dropping and human accident.

5. HANDLING OF GPS

DANGER



- Do NOT work on GPS while piloting.
The work such as installation or maintenance should be carried out on ground.

CAUTION



- Place GPS antenna at highest location as possible for stable GPS signal.
Searching time for GPS signals take longer, and GPS accuracy becomes lower if any obstacles are located near by GPS antenna.

6. OPERATION

Power OFF when starting engine.

Battery voltage varies when the engine starts. It may cause some damages onto the unit. Set the power OFF when starting the engine.

Power Supply 11-30V

Operate the unit within the range of DC11-30V.

Organic solution is prohibited.

Do NOT clean the unit with organic solution like thinner or alcohol etc because most parts are made with plastic. For heavy dirt, soak cloth in synthetic detergent and clean it after wring.

Take note of important data

The unit is not designed for storing the data permanently. Important data should be recorded on the notebook etc.

7. GPS

Approx. $\pm 5\text{m}$ is considered for GPS variation normally under good conditions.
However, this may shift to approx. $\pm 10\text{-}30\text{m}$ under unfavorable conditions.

8. CHIRP TECHNOLOGY

Echo presentation of chirp echo sounder appears differently compared to conventional sounder.

With sweeping range of multiple frequencies, Hondex chirp sounder can utilize more information and achieve higher resolution of screen image such as target fish and sea bottom compared to conventional sounder.

The chirp transducer must be "Thru-Hull" installation.

DESCRIPTIONS

1.FRONT PANEL

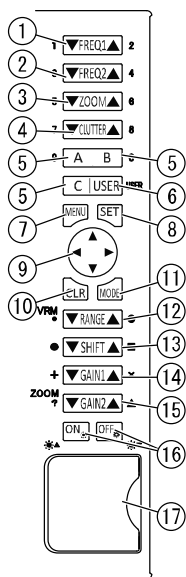

- ⑦ Menu
- ⑧ Set
- ⑨ Direction key
- ⑩ Clear
- ⑪ Mode display switch
- ⑫ Depth
- ⑬ Shift
- ⑭ Gain1 (sensitivity)
- ⑮ Gain2 (sensitivity)
- ⑯ Power On/Off
Brightness adjustment
- ⑰ Card slot for SD and USB device

- ① Frequency1
- ② Frequency2
- ③ Zoom
- ④ Clutter
- ⑤ Setup short-cut key
- ⑥ User key

2. REAR VIEW

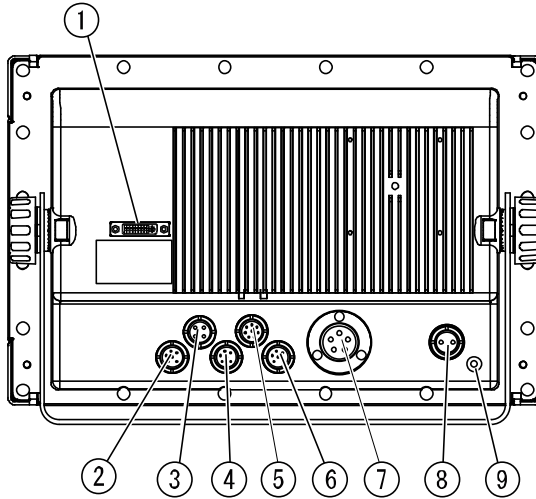

- ① DVI monitor output
- ② GPS (GPS, 6P)
- ③ Remote (4P)
- ④ External input/output (NMEA2, 6P)
- ⑤ Water temp sensor (TEMP, 8P)
- ⑥ External input/output (NMEA1, 6P)
- ⑦ Transducer (5P)
- ⑧ DC Power (2P)
- ⑨ Earth Terminal

HOW TO SEE THE DISPLAY

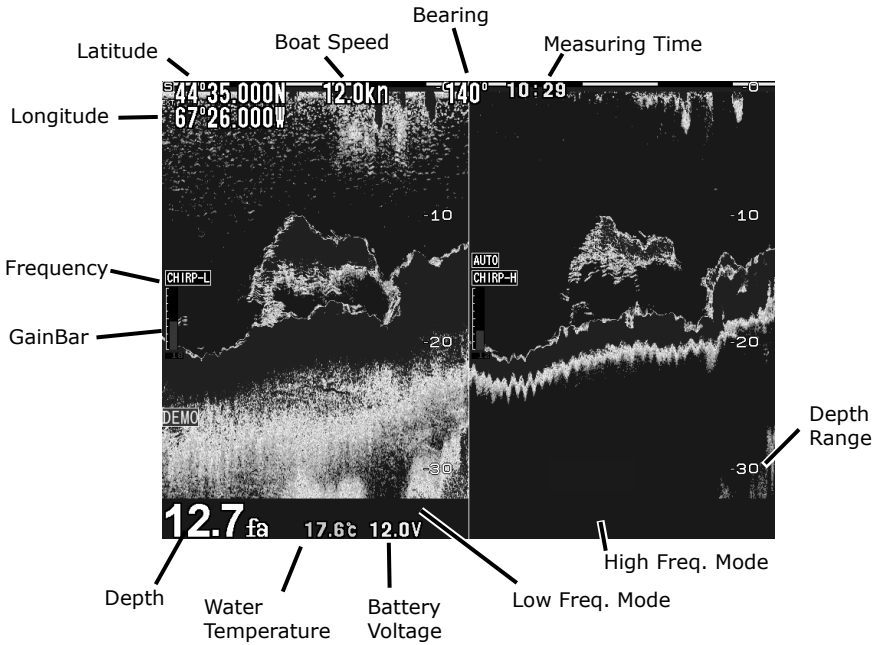

※Water temp sensor : Option

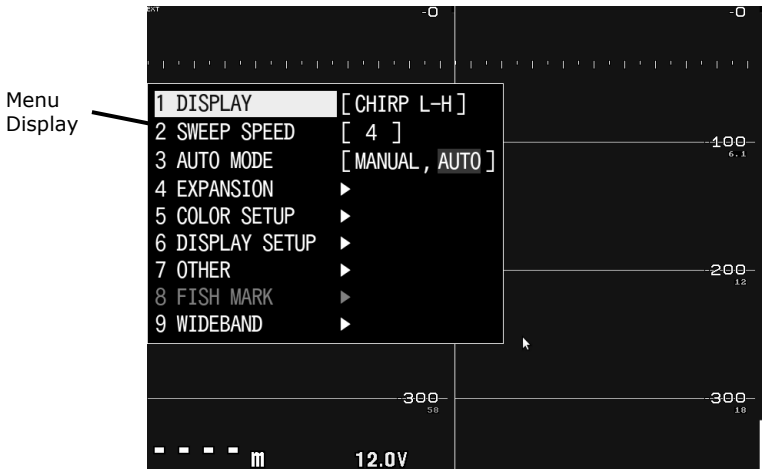

HOW TO OPERATE MENU

How to Operate Menu

Contents of items can be changed by using MENU/DIRECTION/SET/CLR keys.

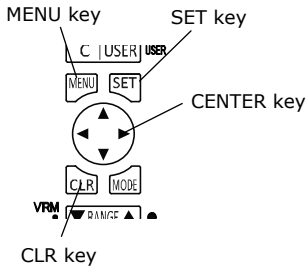

- 1** Press MENU key.
- 2** Use direction key (up/down) to select. Also, input "assigned number" to do the same.
- 3** Use direction key (right) to display next menu page. Press MENU key to return. Repeat steps "2" and "3" to reach the selection of target function.
- 4** "Number input" or "Item selection" to change the set-up.
- 5** Press CLR key to close menu display.

BASIC OPERATION

POWER ON/OFF	13
INITIAL SET-UP(TD LOCATION SET-UP)	14
SCREEN BRIGHTNESS	14
SIMULATION MODE	15
NMEA0183 OUTPUT	16
SCREEN CAPTURE TO USB DEVICE.....	17
INITIALIZE	17

POWER ON/OFF

Power ON/OFF

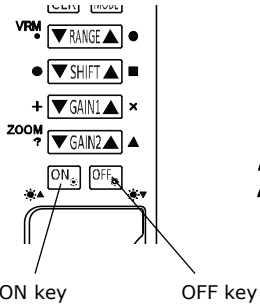

1 Press&Hold ON key to turn on the power. After beep sound followed by caution and chart display.

2 Press&Hold OFF key to turn off the power.

INITIAL SET-UP (TD LOCATION SET-UP)

The following display appears after 1st time power on. Select the proper one.

Select the location of transducer installed.
Use ▲ or ▼ to change the set-up.
Press "MENU" after completing the set-up.

Not selected

IN-HULL

(Select this when using In-Hull or Inside-Case installation.)

THRU-HULL

(Select this when using thru-hull installation.)

Also, this TD set-up can be changed from menu.

(Refer to "TRANSDUCER THRU-HULL / IN-HULL SET-UP" p52.)

SCREEN BRIGHTNESS

Brightness Adjustment

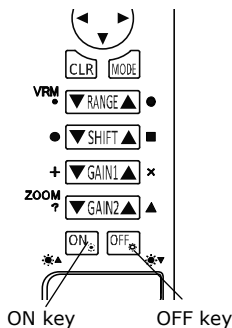

1 Quick Press ON : Brighter
Quick Press OFF : Darker

2 Brightness indicator will disappear itself.
Otherwise, press any keys except ON/OFF to close it.

SIMULATION MODE

SIMULATION

1

Go to 8.OTHERS – 6.OTHER – 5.INITIAL – 2.SIMULATION. Use Direction key to select the different demo mode.

OFF : No simulation mode
ON : Simulation mode

※DEMO icon appears when activating simulation mode.

※Select OFF and press SET key to return to the normal mode.

Caution) Simulation mode is only for practice or exhibition usage.

Information shown on DEMO screen is not actual info such as depth etc.

NMEA0183 OUTPUT

On/Off NMEA Output

- 1** Go to 8.OTHER – 6.OTHER – 4.EXT TERMINAL – 3.NMEA1 OUTPUT or 4.NMEA2 OUTPUT.

ON : Output

OFF : No output

NMEA0183 Output Interval

- 1** Go to 8.OTHER – 6.OTHER – 4.EXT TERMINAL – 1.INTERVAL SETUP1 or 2.INTERVAL SETUP2.

- 2** Each interval can be selected.

※Interval set-up may be disabled when outputting too much data.

※Please refer to p.48 for NMEA0183 output sentence.

BAUD RATE Set-up for NMEA0183 and GPS

- 1** Go to 8.OTHER – 6.OTHER – 4.EXT TERMINAL – 5.NMEA1 PORT BAUD RATE, 6.NMEA2 PORT BAUD RATE.

※GP-16H: 4800, GP-17H(HD): 9600

※Reboot the unit after change of this set-up.

SCREEN CAPTURE TO USB DEVICE

Possible to save the screen image to USB device. PNG format 800x600

Instruction

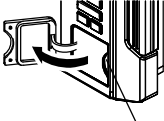

Pull the card slot cover.

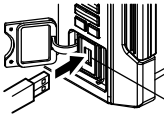

USB connector

USER key

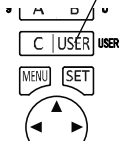

- 1** Pull the card slot cover.
- 2** Insert USB device into the USB connector.
- 3** Press USER key to save the screen shot.
- 4** Use PC etc to see the image.

- ※ · Operation is not guaranteed for all USB memories.
- The USB memory that can be used is up to 32GB (FAT32 format).

INITIALIZE

- 1** Go to 8.OTHER - 6.OTHER - 5.INITIAL - 1.INITIAL ALL
- 2** Press SET key to execute the initialization.

INITIAL ALL : Return to factory set-up. Required to reboot the unit.

※Any erased data cannot be regenerated.

OPERATION OF ECHO SOUNDER

SOUNDER SCREEN	19
DEPTH SET-UP	20
WIDEBAND SET-UP	20
SENSITIVITY	21
EXPANSION MODE	23
EXPANSION AREA	24
WATER TEMP ALARM	25
FISH ALARM	25
DEPTH ALARM	26
WATER TEMP CORRECTION	26
FREQUENCY DISPLAY	27
SWEEP SPEED	27
SOUNDER SET-UP	28
DETAIL SET-UP	28
A MODE	29
BACKGROUND COLOR	29
COLOR CONFIGURATION	30
COLOR ERASE	30
INTENSE LEVEL	31
CLUTTER	31
DEPTH UNIT	32
SCALE LINE	32
SUPER RANGE	32
WATER TEMP GRAPH	33
AUTO RANGE MAX. DEPTH	33
CLEAN ECHO	33
STC	34
OUTPUT POWER	35
PULSE LENGTH	36
SENSITIVITY MODE	37
SOUNDER DISTANCE SCALE	38
BOTTOM HARDNESS FUNCTION	39
PRESET FUNCTON	39
TRANSDUCER THRU-HULL / IN-HULL SET-UP	40
BROADBAND FREQUENCY TUNING	40
LIST OF ECHO SOUNDER MENU	41

SOUNDER SCREEN

Example: Low-Freq – High Freq Display

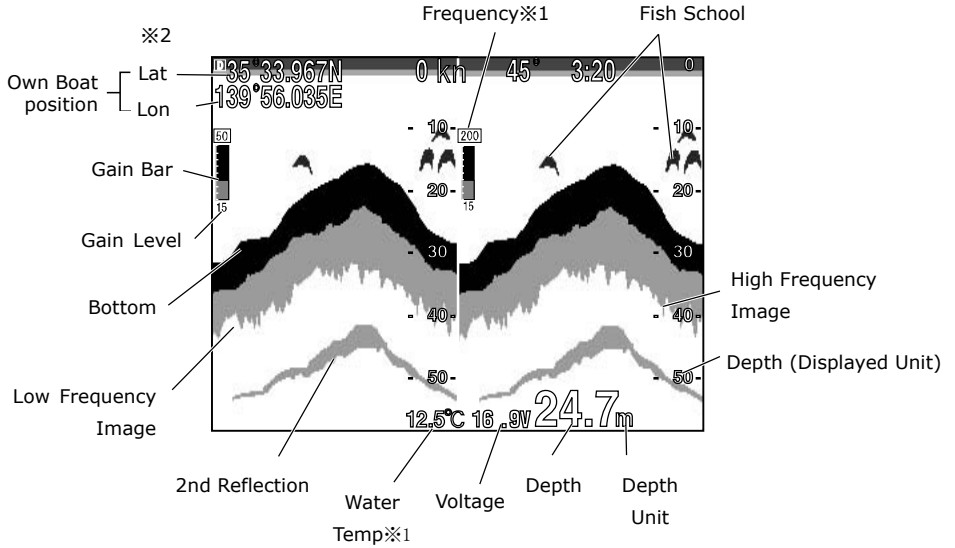

※1 Water temperature

Optional water temp sensor is required to show water temp.

※2 GPS Info

EXT appears when using an external GPS.

DEPTH SET-UP

Depth Range

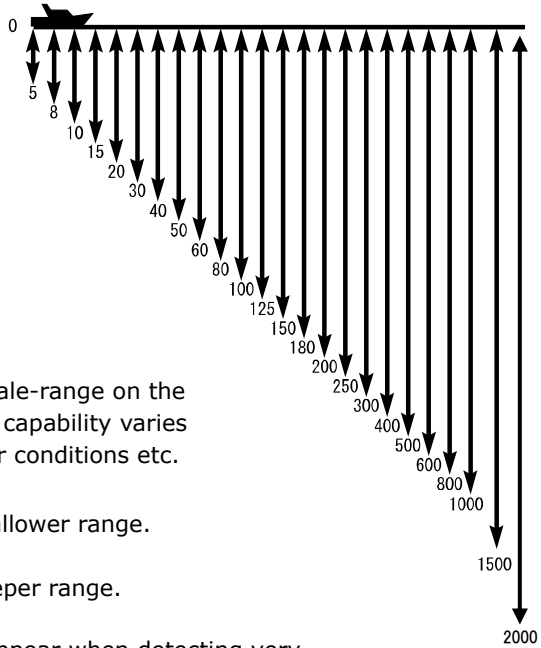

※This is only selected scale-range on the screen. The measuring capability varies depending on the water conditions etc.

1 Press ▲key for shallower range.

Press ▼key for deeper range.

※The depth may not appear when detecting very shallow bottom with very deep range.

WIDEBAND SET-UP

Wideband Frequency

1 Press the set key to select the target pane.
A red frame is drawn on the selected screen frequency.

2 Press FREQ ▲▼key for change frequency.

SENSITIVITY

Whole Display Gain Adjustment

Digital echo sounder is capable of changing the whole past image. This function helps to find the optimized gain set-up for whole image (past recording data) with easy manual operation.

Single Frequency Display

Operation for single frequency display.

- ※Both keys, [GAIN1] and [GAIN2], changes the sensitivity.
- ※Select single or dual frequency display from menu. (→page27)
- ※Dual frequency is selected for default set-up.

[Gain]

Adjust the gain to distinguish the sea bottom and fish school. (0~40: 40 steps of sensitivity level) Optimum sensitivity is to have 2nd reflection of sea bottom and red color bottom.

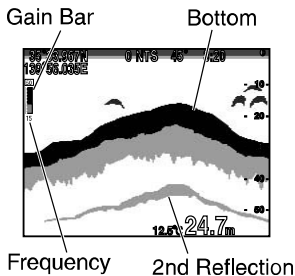

[2nd Reflection]

1st reflection is first reflected sound from sea bottom. 2nd reflection is the sound reflected from the sea surface and reflected again from the sea bottom. Usually, 2nd reflection is located twice deeper than sea bottom (1st reflection).

<Low Gain>

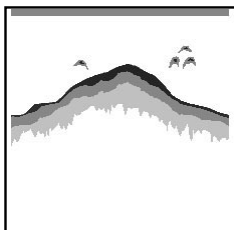

Bottom is green or white color.

<Good>

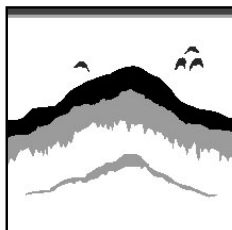

2nd reflection appears ok.
Easy to distinguish fish.

<High Gain>

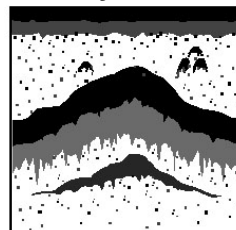

Too much Plankton and noise element.

1

[Lower Sensitivity]

Press ▼key of GAIN1 or GAIN2 to lower the sensitivity and gain bar.

[Higher Sensitivity]

Press ▲key of GAIN1 or GAIN2 to increase the sensitivity and gain bar.

Dual Frequency Display

For dual frequency display, GAIN1 is for right display, and GAIN2 is for left display.

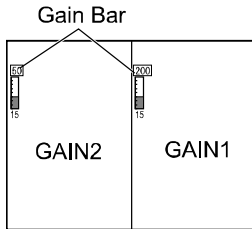

- 1** Adjust the sensitivity of left display with GAIN2 key.
【Lower Sensitivity】
Press GAIN2 ▼ key to lower the sensitivity and gain bar.
【Higher Sensitivity】
Press GAIN2 ▲ key to increase the sensitivity and gain bar.

- 2** Adjust the sensitivity of right display with GAIN1 key.
【Lower Sensitivity】
Press GAIN1 ▼ key to lower the sensitivity and gain bar.
【Higher Sensitivity】
Press GAIN1 ▲ key to increase the sensitivity and gain bar.

EXPANSION MODE

Expansion Mode

【Expansion Display】

Expanded display appears on the left side.

When selecting dual frequency mode, the right-side frequency is applied for expanded display.

1 Press 4.EXPANSION – 1.EXP MODE.

2 OFF : Normal display appears.

BOTTOM LOCK

: Straight bottom contour and expanded area from the bottom.

Auto Zoom

: Set the bottom at center position and expand upper/lower area.

Manual Zoom

: Set the selected location at center and expand upper/lower area. Use Zoom key to move the expansion area.

※Display range varies depending on the expansion ratio.

EXPANSION AREA

Expansion Area

Possible to move the expansion area to either sea surface or bottom side.

※[Zoom] key can be only used during manual expansion mode.

※Expansion ratio can be selected from x2, x4, x8.

※x4: factory set-up

1 Go to 4.EXPANSION – 1.EXP MODE. (→page23)

2 Select MANUAL ZOOM.

3 Use ZOOM key to move the expansion area.
Press ▲key to move to shallow area.
Press ▼key to move to deeper area.

WATER TEMP ALARM

Water Temp Alarm

Alarm is ON within or exceeding the range of 2 different water temps.

※Optional water temp sensor is required for water temp alarm.

e.g) Water temp1 : 5°C
Water temp2 : 10°C

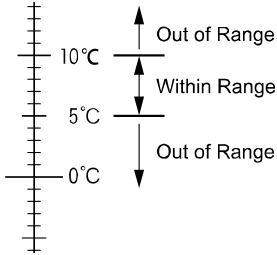

1 Go to 8.OTHER- 5.ALARM – 1.TEMP ALARM – 1.ALARM SET.

2 Alarm set-up
Within Range

: Alarm is ON within the range of 2 selected temps. Temp display blinks.

Out of Range

: Alarm is ON outside the range of 2 selected temps. Temp display blinks.

OFF : Temp alarm is OFF.

3 Set-up the water temp1 and temp2.

※Press CLR key to cancel the alarm.

FISH ALARM

Fish Alarm

Alarm is ON when the fish is detected.

1 Go to 8.OTHER - 5.ALARM – 2.FISH ALARM – 1. ALARM SET.

2 Alarm set-up

S : High sensitivity mode to detect small/big fish schools.

L : Low sensitivity mode to detect only big fish schools.

OFF : Fish alarm is OFF.

Note) Fish alarm may react to the objects other than fish.

DEPTH ALARM

Depth Alarm

Alarm is ON within or exceeding the range of 2 different depths (Depth Set1, Depth Set2).

1 Go to 8.OTHER - 5.ALARM – 3.DEPTH ALARM – 1.ALARM SET.

2 Alarm set-up.

Within range

: Alarm is ON within the range of 2 selected depths.

Out of Range

: Alarm is ON outside the range of 2 selected depths.

OFF : Depth alarm is OFF.

3 Set-up Depth1 and Depth2.

e.g.)

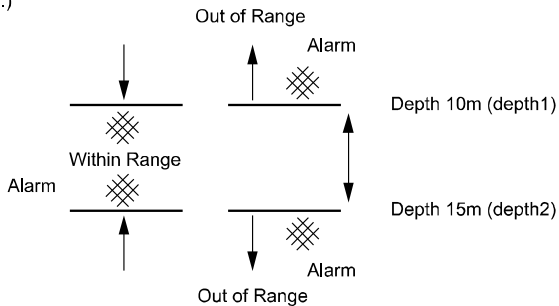

WATER TEMP CORRECTION

Water Temp Correction

Correct the water temp.

1 Go to 8.OTEHR – 6.OTHER - 6.CORRECTION – 4.TEMP CORRECT.

FREQUENCY DISPLAY

Frequency Display

Possible to select dual frequency display as follows.

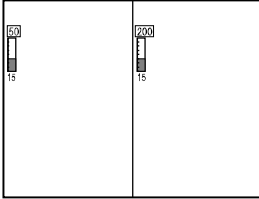

<In case of "50-200">

- 1** Go to 1.DISPLAY.
- 2** Select both(low/high) frequencies on the screen.

※When using Auto-Gain (→page28) , right display is only applied for Auto-Gain function.

SWEEP SPEED

Sweep Speed

【Sweeping Speed】

Sounder display consists of the consecutive latest image (image beneath the vessel) at the right edge and keep shifting the past image to the left side. Sweeping speed is the speed to shift the image. Whole screen appears differently with this set-up value.

【Relation between Sweeping Speed and Sounding Rate】

Sweeping speed can be selected from 8 different types. The following is the reference of sounding rate for each set-up.

Menu Set-up	Sweep Speed / Sounding Rate
× 3	3/1
× 2	2/1
4	1/1
3	1/2
2	1/4
1	1/8
Freeze	Freeze

↑ Fast
↓ Slow

- 1** Go to 2.SWEEP SPEED.
- 2** Select one.
 ※MENU varies depending on each mode.
 (→page 40).
 - CHIRP : OFF, 1, 2, 3, 4
 - FISH SYMBOL(ON) : OFF, 4
 - TRADITIOAL : OFF, 1, 2, 3, 4, S, ×2, ×3

SOUNDER SET-UP

Select AUTO or MANUAL set-up for the depth (range) & sensitivity (gain).

1 Go to 3.AUTO MODE.

2 AUTO enables the selected AUTO functions in the following detailed set-up.
AUTO or MANU indicator appears above gain bar.

DETAIL SET-UP

[Auto Gain] Automatic gain control

1 Go to 8.OTHERS – 2.SPECIAL SETUP – 7.AUTO MODE SERTUP.

Select AUTO GAIN.

2
OFF : Disable
LOW : Normal
HIGH : High gain

[Depth Range] Set-up Auto Range/Shift.

1 Go to 8.OTEHRS – 2.SPECIAL SETUP – 7.AUTO MODE SETUP.

Select 2.AUTO RANGE.

2
OFF : Disable
RANGE : Auto-range
SHIFT : Auto-shift

※Shift key does not work when AUTO RANGE is selected.

A MODE

A Mode

A mode appears between sounder image and depth indication.
The width changes depending on the strength of reflected echo signal.

- 1** Go to 7.DISPLAY SETUP – 1.A-MODE.
- 2** Select one.
ON
OFF

BACKGROUND COLOR

Background Color

Visual image of display looks differently by surrounding brightness. It is easier to see the image by selecting the background color from 4 different colors.

- 1** Go to 6.COLOR SETUP – 1.BACKGROUND.
- 2** Select one.

COLOR CONFIGURATION

Color Configuration

Reflected signal of sound wave is converted into 17 ranks of digital signal according to the strength of response. Color configuration is the color set-up for 16 ranks except background color.

Sounder image is shown by the color configuration. The displayed color shows the strength of reaction. Also, specific reaction can be emphasized by changing the color configuration.

- 1** Go to 6.COLOR SETUP – 2.COLOR CONFIG.
- 2** Select one.

COLOR ERASE

Color Erase

Set-up the erase level so that fish schools can be seen clearly.

- 1** Go to 6.COLOR SETUP – 3.COLOR ERASE.
- 2** Select one.

INTENSE LEVEL

Intense Level

This set-up shows more color of strong reflection (signal).

1 Go to 6.COLOR SETUP – 4.INTENSE COL.

2 Select one.

STD
HI
MAX ↓

CLUTTER

Clutter

Fish school and bottom are displayed with the set-up of reflected echo strength and color tone. "Clutter" easily distinguishes the fish school by erasing the color from weakest reflection such as plankton or dirt under the water.

1 Go to 6.COLOR SETUP – 5.CLUTTER.

2 STD
1
2
3 ↓ Less noise toward higher number.

DEPTH UNIT

Depth Unit

Select from "meter", "feet", "fathom", or "Brazas".

1 Go to 8.OTHER - 1.DEPTH UNIT.

2 Select one.

SCALE LINE

Scale Line

Horizontal line (scale line) appears on the screen.

1 Go to 7.DISPLAY SETUP - 2.SCALE LINE.

SUPER RANGE

Super Range

Whole past image changes automatically according to the current depth (displayed depth range on screen) if changed any.

1 Go to 7.DISPLAY SETUP - 3.SUPER RANGE.

WATER TEMP GRAPH

Water Temp Graph

Water temp graph appears. Easy to see the fishing points by knowing the variation of water temp and tide change.

- 1** Go to 7.DISPLAY SETUP – 4.TEMP GRAPH.

※Optional water temp sensor is required to show the graph.

AUTO RANGE MAX. DEPTH

Auto Range Max. Depth

Set-up the max. depth when using auto range.

- 1** Go to 8.OTHER – 2.SPECIAL SETUP – 1.AUTO RANGE MAX.

- 2** Select one.

CLEAN ECHO

Clean Echo

Reduce the desynchronized noise such as other sounder, electronics noise, air bubble, and mechanical noise.

- 1** Go to 8.OTHER – 2.SPECIAL SETUP – 2.CLEAN ECHO.

- 2** Select one.

STC Setup

Reduce the sensitivity of shallow water area by eliminating the noise signals such as plankton and air bubbles.

1 Go to 8.OTHER – 2.SPECIAL SETUP – 3.STC SETUP.

2 Set-up STC

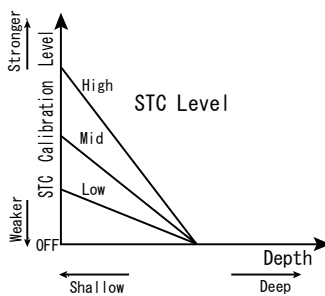

〈Low-Freq STC Level〉 〈High-Freq STC Level〉

Set-up STC level for either low-freq or high-freq.

Low sensitivity at shallow area with stronger STC.

4 different STC level: OFF, Low, Mid, High

OFF: Weakest, H: Strongest

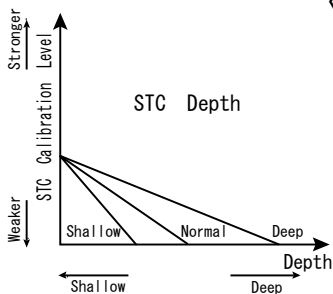

〈Low-Freq STC Depth〉〈High-Freq STC Depth〉

Set-up the target depth for STC

adjustment (low-freq or high-freq)

Deeper the depth is selected, selected STC level is affected to deeper water.

3 different STC target depth: Shallow, Normal, Deep.

Shallow: 0~50m, Normal: 0~150m,

Deep: 0~300m

OUTPUT POWER

Output Power

1 Go to 8.OTHER - 2.SPECIAL SETUP -
4.OUTPUT POWER.

2 OFF, LOW, or HIGH
(OFF: No transmit. Only active receiver.)

※Normal case: Set to HIGH.

PULSE LENGTH

Pulse Length

The pulse length is the ultrasonic length transmitted each time. 3 selections to choose from. The resolution may vary for each option.

1 Go to 8.OTHER – 2.SPECIFAL SETUP – 5.PULSE LENGTH.

2 Short : High resolution but shallow depth penetration. Low power consumption.

STD : Standard (Normal) level

Long : Low resolution but deep depth penetration.

Example

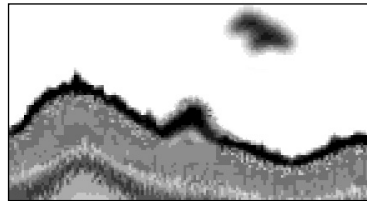
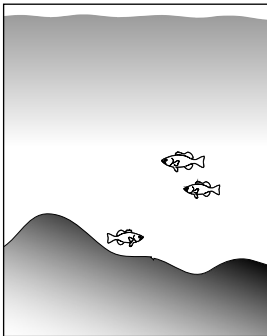

[Long Pulse Length]
2 fish image combined together



[Short Pulse Length]
Better target separation.

SENSITIVITY MODE

Sensitivity

Set-up the sensitivity level of sounder.

1 Go to 8.OTHER – 2.SPECIAL SETUP – 6.SENSITIVITY.

2 STD : Standard (Normal) level
HIGH : High sensitivity level

※Use GAIN1/GAIN2 key (→page21) for everyday's Gain (sensitivity) set-up.

SOUNDER DISTANCE SCALE

Distance scale displayed on the sounder screen.

To give you an idea of how far away the target is located from an own vessel.

1 Go to 7.DISPLAY SETUP – 5.DIST SCALE.

2 OFF : No show
TOP : Scale display on the top
BOTTOM : Scale display at the bottom

※Distance scale number does not appear until echo image reaches to the left edge screen.

※No distance scale number when the distance is 20m or less.

BOTTOM HARDNESS FUNCTION

Bottom Hardness Function

Bottom Hardness Level : 0~20
Hard Bottom : Higher value
Soft Bottom : Lower value
The value appears on the upper left of screen.
Also, bottom hardness graph appears at the bottom.



Bottom
Hardness
Level

- 1 Go to 7.DISPLAY SETUP – 6.BOTTOM HARDNESS SETTING – 4.BOTTOM HARDNESS GRAPH.

Note) Applicable for shallow water.
The value varies depending on the conditions of transducer installation etc.

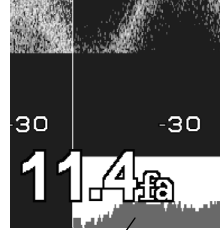

Bottom Hardness

PRESET FUNCTION

PRESET FUNCTION

Each set-up parameter can be saved and recall by short-cut keys of A/B/C.

- 1 Press&hold A, B or C button to save the selected parameter.
- 2 Press A, B or C button to recall the saved parameter.

TRANSDUCER THRU-HULL / IN-HULL SET-UP

TD Location

1 Go to 8.OTHER – 2.SPECIAL SETUP – 8.TD LOCATION.

2 Select one.

THRU-HULL-A :Custom. Not to be used normally.

THRU-HULL-B :Normal. Select this when using thru-hull installation.

IN-HULL-A :Select this when using in-hull or inside-case installation.

IN-HULL-B :Custom. Only for the case IN-HULL-A is not working properly.

BROADBAND FREQUENCY TUNING

Frequency Tuning

Go to 9.WIDEBAND

CHIRP : n/a

TRADITIONAL w/ wideband transducer : Choose Freq to use.

SET-L : Low Freq

SET-H : High Freq

TRADITIONAL w/ conventional transducer : n/a

LIST OF ECHO SOUNDER MENU

Menu Item

※ Factory set-up

1. DISPLAY	(→page19,27)	CHIRP L-H, CHIRP L-L, CHIRP H-H, CHIRP L, CHIRP H, CHIRP H-L In case of TD361.
2. SWEEP SPEED	(→page27)	OFF 1 2 3 4 S x2 x3 ※S,x2,x3 not available for CHIRP TD
3. AUTO MODE	(→page28)	MANUAL, AUTO
4. EXPANSION	1. EXP. MODE (→page23)	OFF , BOTTOM, AUTO ZOOM, MANUAL ZOOM
	2. EXP. RATE	x2, x4 , x8
5. FISH SYMBOL	1.FISH SYMBOL	OFF , ON, ON(SIZE)
	2.FISH DEPTH	OFF , FROM SURFACE, FROM BOTTOM
※NOT FOR CHIRP TD	3.SYMBOL TYPE	FISH , STREAMER, FRAME
	4. SYMBOL CALIB	
6. COLOR SETUP	1. BACKGROUND (→page29)	BLACK, BLUE , WHITE, D.BLUE
	2. COLOR CONFIG (→page30)	4 (0~7)
	3. COLOR ERASE (→page30)	OFF (OFF~12)
	4. INTENSE COL (→page31)	STD , HI, MAX
	5. CLUTTER (→page31)	STD , 1, 2, 3
7. DISPLAY SETUP	1. A-MODE (→page29)	OFF , ON
	2. SCALE LINE (→page32)	OFF , ON
	3. SUPER RANGE (→page32)	OFF , ON
	4. TEMP GRAPH (→page33)	OFF , ON
	5. DIST SCALE (→page38)	OFF , TOP, BOTTOM
	6. BTM HRADNESS SETTING (→page39)	1.BTM HARDNESS 0 (-2~2) OFFSET 2.BTM HARDNESS AVE 1 , 2, 3 3.BTM HARDNESS SENS H, ·, ·, ·, ·, · , L 4.BOTTOM HARDNESS OFF , ON GRAPH
8. OTHER	1. DEPTH UNIT (→page32)	m , ft, fa, br
	2. SPECIAL SETUP	1. AUTO RANGE MAX (→page33) 30m. 50m. 100m. 300m. 500m . 1000m 2. CLEAN ECHO (→page33) OFF, L , M, H 3. STC SETUP(→page34) 1. STC (LOW FREQ) OFF, L, M , H 2. STC (HIGH FREQ) OFF, L, M , H 3. STC DEPTH (LOW FREQ) SHALLOW, NORMAL , DEEP 4. STC DEPTH (LOW FREQ) SHALLOW, NORMAL , DEEP 4. OUTPUT POWER (→page35) OFF, LOW, HIGH 5. PULSE LENGTH (→page36) S, STD , L 6. SENSITIVITY (→page37) STD , HIGH

7. AUTO MODE SETUP	
1. AUTO GAIN	OFF , LOW , HIGH
2. AUTO RANGE	OFF , RANGE , SHIFT
8. TD LOCATION	IN-HULL-A , IN-HULL-B , (→page40) THRU-HULL-A , THRU-HULL-B
9. OTHER SPECIAL SETUP	
1. FINDEER DETAIL SETUP 1	
1. L FREQ. MIN DEPTH LV	0dB (-20~+12db)
2. H FREQ. MIN DEPTH LV	0dB (-20~+12db)
3. L FREQ. MIN DEPTH	0.37 m (0.25~6.11m)
4. H FREQ. MIN DEPTH	0.37 m (0.25~6.11m)
5. L FREQ. AUTO GAIN	±0 (-5~+5) CORRECT.
6. H FREQ. AUTO GAIN	±0 (-5~+5) CORRECT.
2. FINDER DETAIL SETUP 2	
1. BANDWIDTH	WIDE , STD , NAR-1 , NAR-2
2. TARGET DEPTH RANGE	X1 , x2 , AUTO
3. DEPTH MEAS	AUTO , RIGHT-DISP
3.EXT SYNC	OFF, ON
4.HEAVE ADJUST	OFF, ON
5.ALARM	1. TEMP ALARM 2. FISH ALARM 3. DEPTH ALARM
6.OTHER	1. MEMORY CARD 2. UNIT SWITCH 3. CORRECTION 4. EXT TERMINAL 5. INITIAL
9.WIDEBAND	1. MODE TRADITIONAL, CHIRP
	2. SET-L 38kHz,40kHz,45kHz,50kHz, 55kHz,60kHz,65kHz,70kHz
	3. SET-H 130kHz,140kHz,150kHz, 160kHz,170kHz,180kHz, 190kHz,200kHz,210kHz, 220kHz

REFERENCE DOCUMENT

DIMENSIONAL DRAWING	45
CONNECTION WITH MAIN UNIT	46
CONNECTOR DIAGRAM	47
GPS ANTENNA MADE BY OTHER COMPANY	47
NMEA CONNECTOR	48
NMEA0183 OUTPUT SENTENCE	48
MAIN UNIT INSTALLATION	49
BUILT-IN INSTALLATION	50
TRANSDUCER INSTALLATION	52
1. INSIDE-HULL	53
2. THRU-HULL	53
WATER TEMP. SENSOR INSTALLATION	54
STANDARD CONFIGURATION	55
OPTIONS	56
THEORY OF ECHO SOUNDER	57
TROUBLE SHOOTING	59
SPECIFICATIONS	62

DIMENSIONAL DRAWING

1.MAIN UNIT

Unit : mm

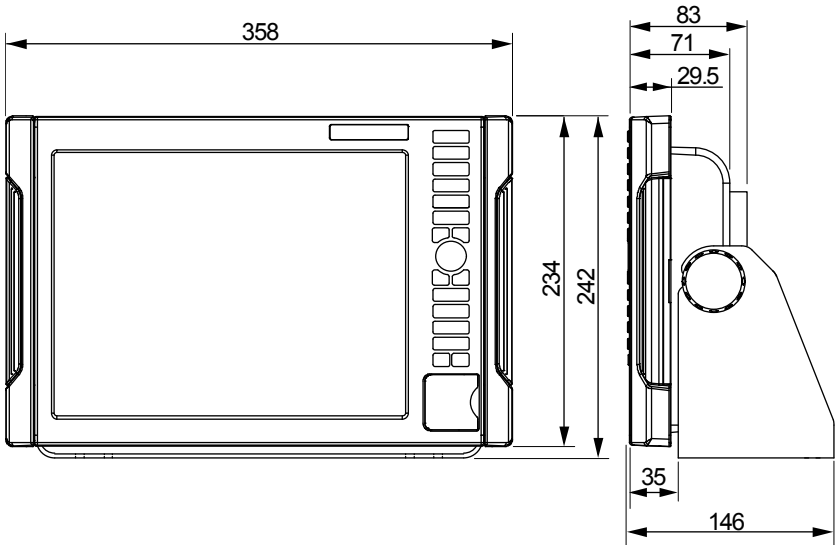

2.BRACKET

Unit : mm

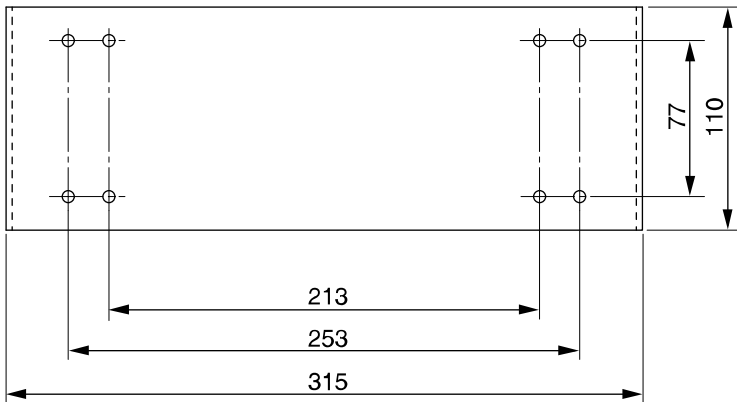

CONNECTION WITH MAIN UNIT

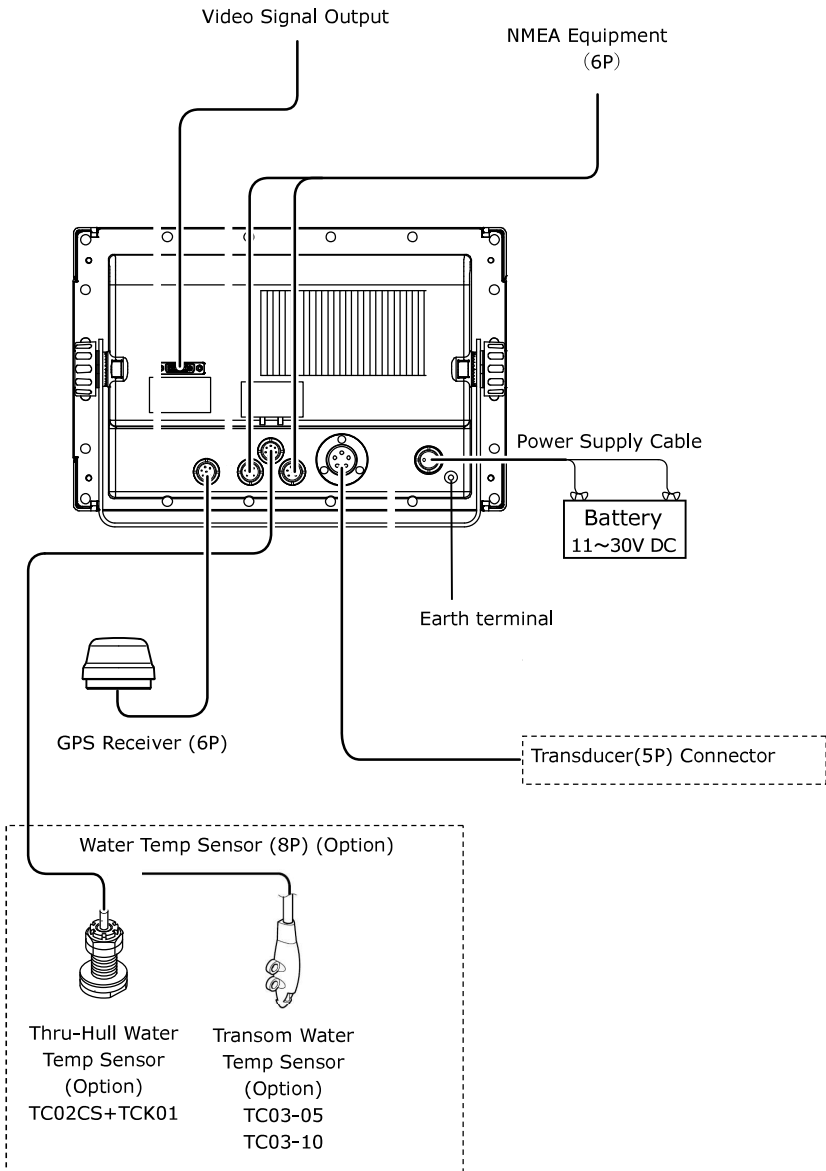

CONNECTOR DIAGRAM

Caution: Connectors on display unit.

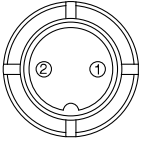

1. Connector for Power Supply
1. Power Supply (+) 11~30V
 2. Power Supply (-)

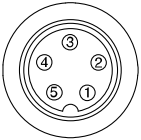

2. Connector 5P for Transducer
1. freq A(+) / CHIRP-L
 2. freq B(+) / CHIRP-H
 3. Shield
 4. freq B(-) / CHIRP-H
 5. freq B(-) / CHIRP-L

(Example) TD Line Info(TD361)

5P Spec	
①	-(Black) CHIRP-L
②	-(Green)CHIRP-H
③	Shield
④	+(Red) CHIRP-H
⑤	+(White) CHIRP-L

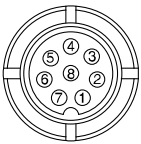

3. Connector for Water Temp Sensor
1. N/A
 2. N/A
 3. N/A
 4. N/A
 5. N/A
 6. Water Temp Sensor(+)
 7. Water Temp Sensor(-)
 8. N/A

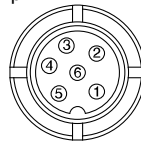

4. Connector for External Input/Output
1. GND
 2. Data Input(-)
 3. Data Input(+)
 4. N/A
 5. Data Output
 6. DC10.5V (200mA)Output

GPS ANTENNA MADE BY OTHER COMPANY

※ The performance&accuracy is not covered by the warranty when using GPS antenna of different brand.

NMEA CONNECTOR

Input/Output Connector

To be used when connecting to other device.

Data Format	Baud Rate	Format
NMEA0183 GGA, GLL, VTG, RMC, APB, XTE, BOD, DBT, MTW, HDG, HDT	4800, 9600, 38400bps	Start bit=1, Data bit=8 Parity bit=None, Stop bit=1

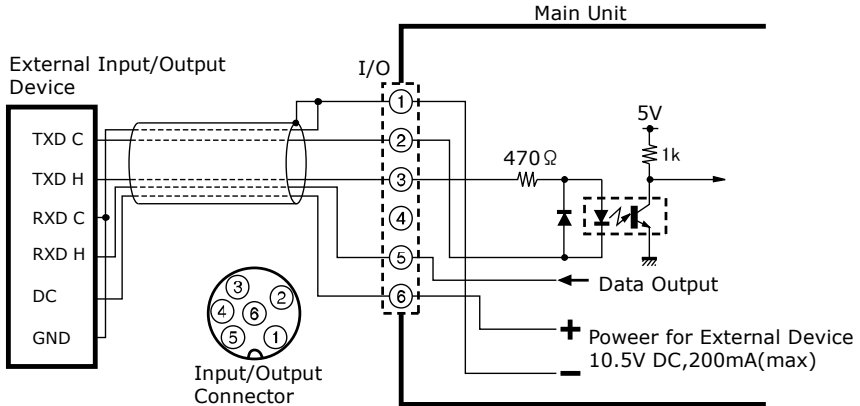

NMEA0183 OUTPUT SENTENCE

The following sentence is output.

The output interval can be set from OFF, 1sec, 2sec, 4sec.

※GGA, GLL, VTG, RMC: Available only when receiving the data from GPS receiver.

※Same output interval is used for HDG and HDT.

※The output interval might be longer when selecting many items.

※Factory set-up

1sec: DBT, MTW OFF: Other items

Example for output sentence

\$GPGGA,110147,3443.160,N,13726.746,E,1,09,001,00070,M,0025,M,,*55

\$GPGLL,3443.16,N,137.26,E*55

\$GPVTG,118.9,T,,000.0,N,000.0,K*2C

\$GPRMC,110146,A,3443.160,N,13726.746,E,000.0,118.5,270707,,*15

\$GPAPB,A,A,00.001,R,N,V,001.4,T,000,001.4,T,,*77

\$HCHDG,000.0,,,,*5C

\$GPXTE,A,A,00.001,R,N*71

\$GPBOD,001.4,T,,000,1000*10

\$GPBWC,110100,3508.785,N,13727.496,E,001.4,T,,025.63,N,000*69

\$SDDBT,209.6,f,63.9,M,34.9,F*28

\$SDMTW,27.6,C*1A

MAIN UNIT INSTALLATION

⚠ WARNING

- Install the unit firmly.
If not, it may cause the human injuries.
※ Install the unit correctly according to the following instruction.

⚠ CAUTION

- Do NOT install the unit where rain or spray dashes hit directly.
It causes the firing and electric shock.

【Procedure of Installation】

<Installation of Main Unit>

Fix the unit with enclosed screws by using bracket holes (4 locations).
Refer to the picture below.

Please fix main unit with four mash-room head tapping screws 5x20.

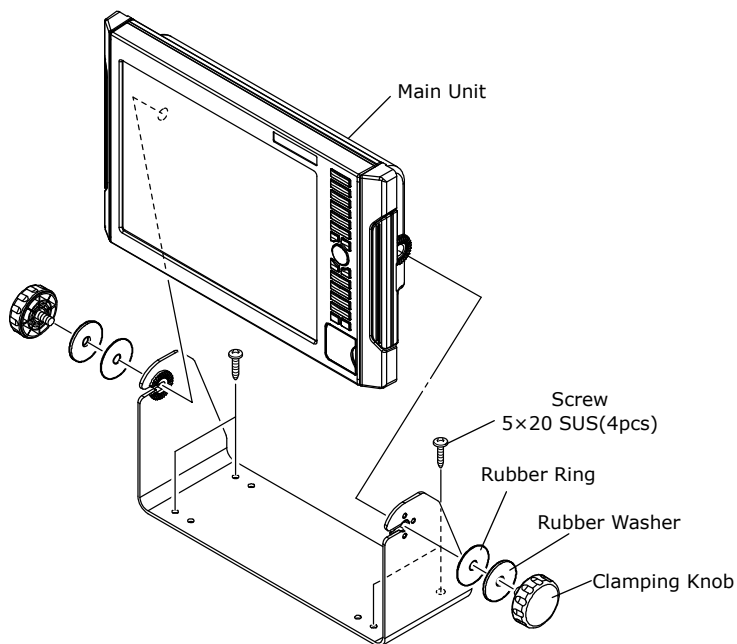

BUILT-IN INSTALLATION



WARNING

- Install the unit firmly.
If not, it may cause the human injuries.
- ※ Be sure to follow the instruction below and official installation method.

Fix the unit by using 4 holes on the front panel.

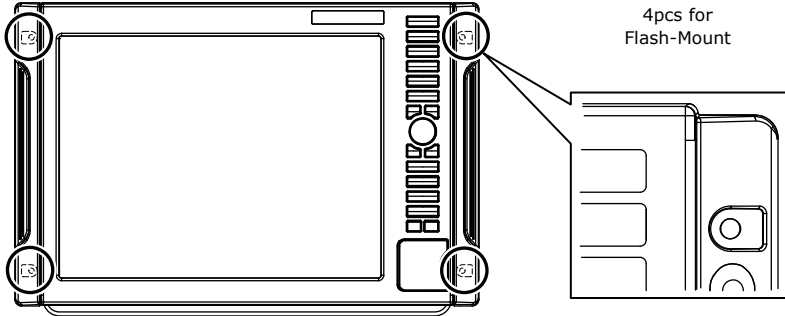

1. Refer to the following figure for fixation holes.

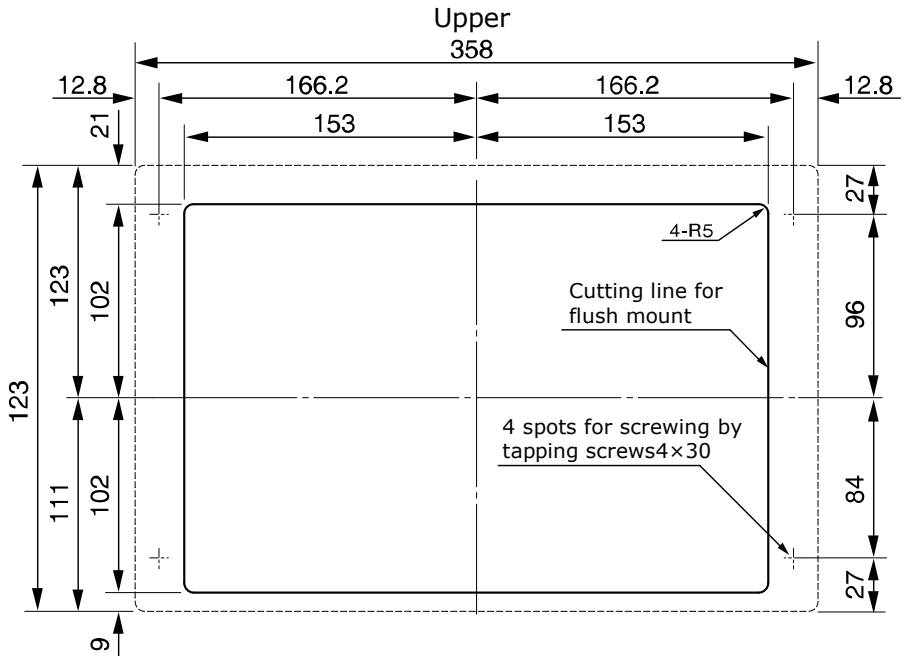

2. Raise 2pcs side covers.

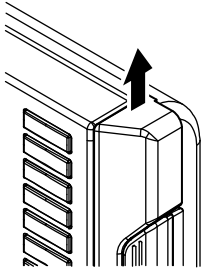

3. Remove the covers.

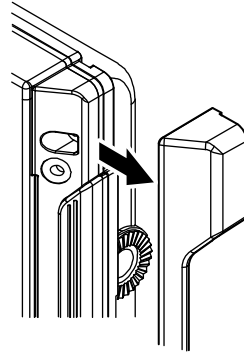

4. Flash-mount it.

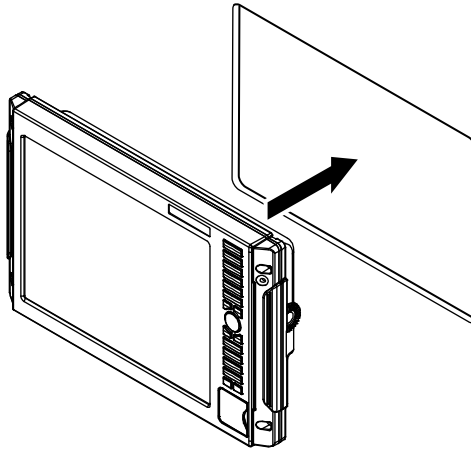

5. Fix with 4pcs 4x30 screws.

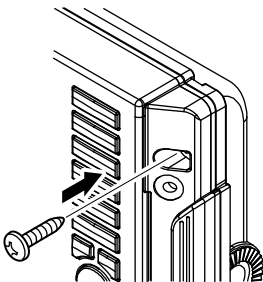

6. Put the side covers back.

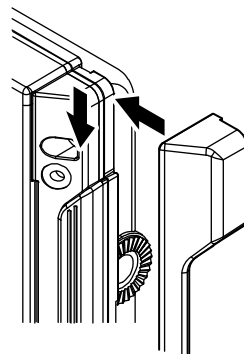

TRANSDUCER INSTALLATION

⚠ DANGER

- Any works on the vessel are very unstable and risky.
Installation/maintenance of transducer should be handled after landing the vessel on ground or fixing the vessel at shipyard etc.
If not, it may cause serious injuries.

⚠ WARNING

- ⊘ •Be sure to ventilate well inside the vessel when installing the transducer at the bottom of vessel.
Volatile gas from solvent etc causes the toxic symptoms.
- ! •Water proof treatment is required for Thru-Hull installation.
If not, it causes the marine accident.
- Do not operate the electronic tools with wet hands.
It causes electronic shock.
- ! •Thru-Hull installation is required for Chirp/Wideband transducers.
If not, it causes the damage onto transducers.

【Installation Method】

The following installations can be applied for conventional transducers.

Please refer to each instruction.

1. Inside-Hull
2. Thru-Hull

※These methods prohibit the use of aluminum vessels for the risk of corrosion.

※Be careful about the following points when using the method 1 .

No protruding object in front of transducer such as screw out deckplate and drain.

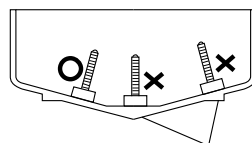
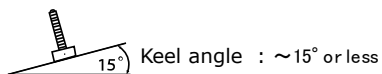
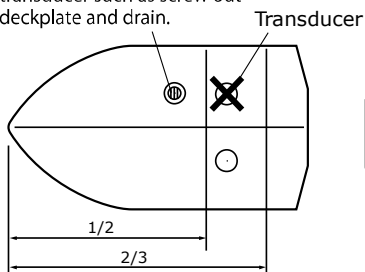

Do not install the transducer at the locations having obstruction like keel etc.

1. INSIDE-HULL

※Effective for FRP vessels with single hull layer of 10mm or less.

※Size and shape vary for each transducer.

Look for the best picture location before the fixation by putting adequate water on the transducer surface and vessel bottom followed by pressing the transducer onto the vessel bottom.

- (1) Polish the adhesive surface (transducer bottom surface and vessel bottom) well with sandpaper (#240 or around) and alcohol in order to remove oil, water, and dirt on the surface.
- (2) Put silicon bond on the adhesive surface (transducer bottom surface and vessel bottom) and press firmly for the bonding so that no air bubble is contained inside.

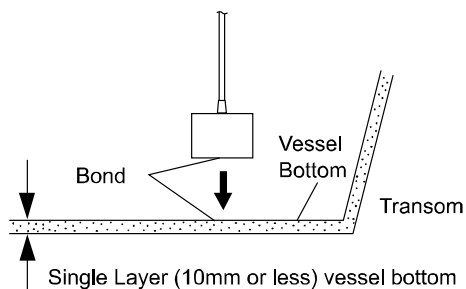

2. THRU-HULL

(1) Make hole of $\phi 25$ at the vessel bottom. (Aluminum vessels are not subject to the installation for the risk of corrosion.)

(2) Insert the screw part of transducer into the hole and fix it with 1pc cork washer, 1pc washer, and 1pc nut. (Extra cork washer is for spare.)

※Execute the waterproof care for the junction part.

For tilted hull, use a block etc to face directly to the vessel bottom.

※Size and shape vary for each transducer.

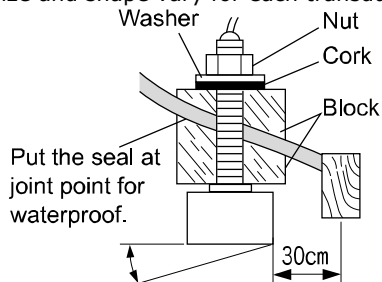

Keep the inclination of transducer surface below 10° or less.

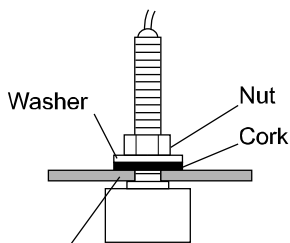

Put the seal at joint point for waterproof.

WATER TEMP. SENSOR INSTALLATION

※Water temp sensor: Option

▲ DANGER

- Any works on the vessel are very unstable and risky.
Installation/maintenance of water temp sensor should be handled after landing the vessel on ground or fixing the vessel at shipyard etc. If not, it may cause serious injuries.
- Do not operate the electronic tools with wet hands.
It causes electronic shock.

【Installation of Thru-Hull Water Temp Sensor (15m)】

※For FRP vessel only.

(The use of this sensor is prohibited for aluminum vessels due to the risk of corrosion.)

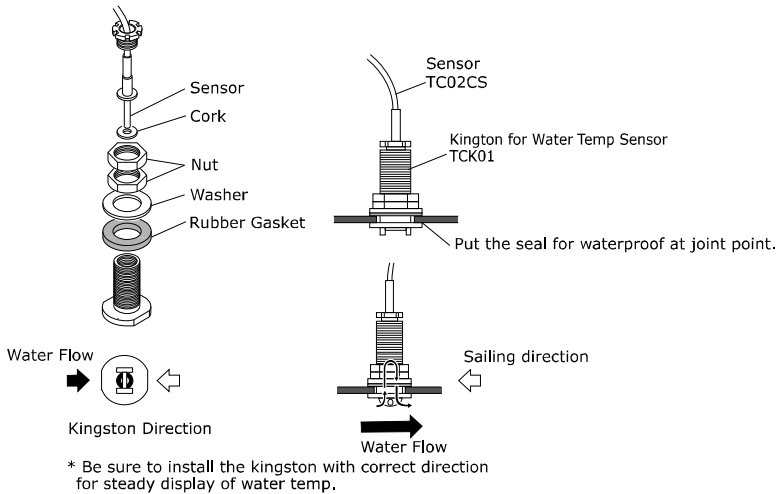

【Installation of Transom Water Temp Sensor】

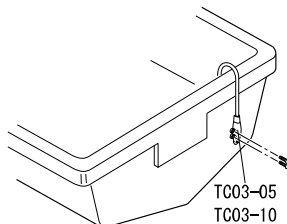

STANDARD CONFIGURATION

Main Unit 12.1"

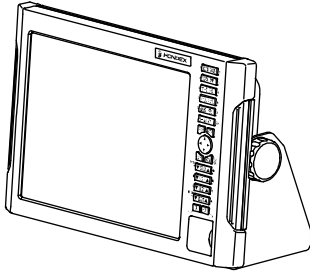

Bracket 1pc
Clamping Knob 2pcs
Rubber Washer 2pcs
Bracket Washer 2pcs

Screws for Main Unit

5×20 SUS×4pcs



Screws for Remote

4×30 SUS×4pcs



Power Supply Cable (DC07) 2P 2m

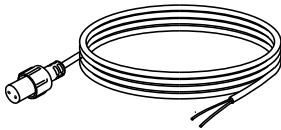

Operation Manual

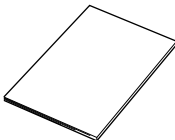

Paper Template for Built-in Fixation

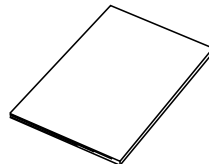

OPTIONS

Thru-Hull Water Temp Sensor
(TC02C + TCK01)
(8P 15m)

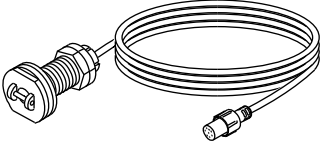

Transom Water Temp Sensor
TC03-05 (8P 5m)
TC03-10 (8P 10m)

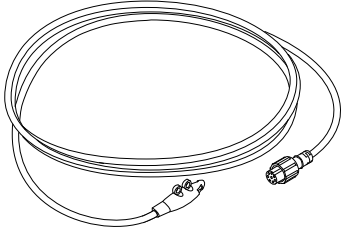

GPS Receiver

GP-16H

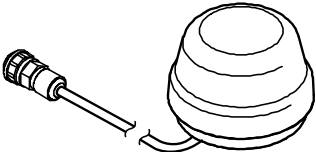

GP-17H/17HD
*GP-17HD(heading sensor included)

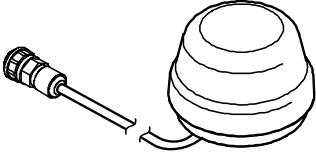

THEORY OF ECHO SOUNDER

1. Theory of Echo Sounder

- Theory of echo sounder is same as echo among hills.

Ultrasonic wave transmitted from the transducer directly beneath the vessel is reflected at the sea bottom and received by transducer.

Echo sounder indicates the depth by calculating the round-trip time to distance. Also, the unit shows the color image of fish school size/density or sea floor condition according to the strength of reflected wave.

Ultrasonic wave runs at 1500m/sec inside the water. Therefore, the depth to fish school and sea bottom can be captured by calculating the round-trip time.

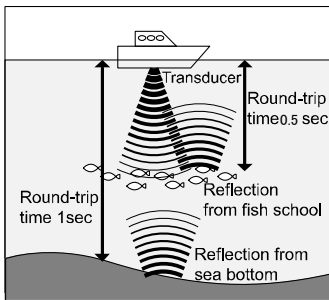

e.g.) 1sec is round-trip time from sea bottom.

$$\begin{aligned} \text{Round-trip distance} &= 1500\text{m/sec} \times 1\text{sec} \\ &= 1500\text{m} \end{aligned}$$

The depth is half the size, so

$$\begin{aligned} \text{Depth} &= 1500\text{m} \div 2 \\ &= 750\text{m} \end{aligned}$$

0.5sec is round-trip time from fish school

$$\begin{aligned} \text{Round-trip distance} &= 1500\text{m/sec} \times 0.5\text{sec} \\ &= 750\text{m} \end{aligned}$$

The depth is half the size, so

$$\begin{aligned} \text{Depth} &= 750\text{m} \div 2 \\ &= 375\text{m} \end{aligned}$$

- Display Method

Current image is shown at 1st line of right edge after processing the reflected wave of transmitted ultrasonic. The line image previously located at the right edge moves to one line to the left.

Keep executing this operation to create the cross section view.

Therefore, the latest image beneath the vessel is located at the right edge. More left side the image moves, more past image the screen shows.

You can assume that echo sounder screen shows the image from the side view.

The sea floor shape can be only captured when sailing the vessel. No matter how the bottom is shaped, the image shows the flat bottom if the vessel is stopped.

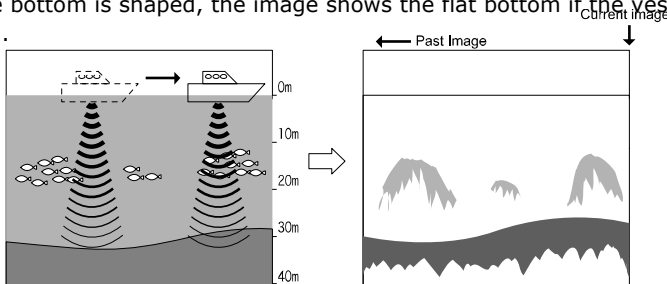

Caution : There is no relationship between vessel speed and image line speed.

2. Distinguish of Fish School

- Important tip is comparison between fish school image and actual fish.

Possible to judge the fish type to some extent from the image of fish school. The shape of fish school changes even for same fish group by time (day/night, season, current change).

The important tip is to distinguish the fish type image and actual catch and look for the point.

3. Distinguish of Fish Quantity

- Distinguish fish quantity from density/size of fish school.

Higher density of fish school has stronger reflected wave. Therefore, the fish density can be seen from the color strength of image.

It is wrong that fish quantity is large for large image on the screen. Fish school located deeper area tends to appear bigger compared to the one at shallow water. This is because the width of transmitted wave becomes wider as it goes deeper. The reflected ultrasonic wave becomes bigger as the distance (depth) gets further. The important tip to distinguish the fish quantity is to know fish school located at deeper water appears bigger.

Judge from size of fish school and color strength.

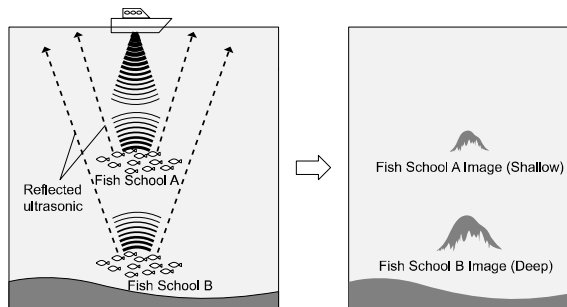

4. Distinguish of Sea Floor Condition

- There are many types of sea floor conditions such as rocky, sandy, or muddy.

The condition can be judged by the upper/lower width of sea floor image and 2nd echo. The reflection is stronger for hard bottom such as rocky area. The image width is thicker, and 2nd echo tends to appear.

On the other hand, the reflection is weaker for soft bottom such as sandy and muddy area. The image width is thinner, and it's harder to have 2nd echo.

<Rocky Area>

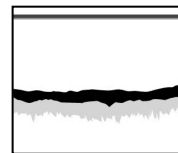

<Sandy or Muddy Area>



TROUBLE SHOOTING

- When the unit has any problems, please check the following points before returning the unit for repair.

Symptom	Cause	Remedy
Power cannot be turned ON.	Voltage of battery is lower than standard value (11V).	Recharge the battery.
	Contact of power connector is poor.	Retighten it. Remove and clean the rust/dust. Replace it in the case of corrosion. <ul style="list-style-type: none"> · Replace the power cable. · Replace the connector on the unit.
	Wrong connection of power. Opposite polarity + - .	Check the polarity and connect it properly.
	Cut the wire inside power cable.	Exchange to new power cable.
	Blown fuse.	Send it for repair.
No display on screen.	Brightness is set to minimum level.	Adjust the brightness. (Refer to [SCREEN BRIGHTNESS])
Latitude/longitude of own vessel are not indicated.	Data from satellite cannot be received well.	Check GPS antenna and cable.
	Data is not sent from GPS receiver. (In case of using external GPS receiver)	Check setting of data output (GGA) from GPS receiver.
	Numbers of received satellite is less (0~3)	Wait for a while. (Approx. 5~30 minutes)
Display cannot be moved.	Cursor is shown on the screen.	Erase the cursor. (Refer to [CURSOR])
Just above on display and north of map are swerved.	Course-up function is set.	In case you want to set just above on display to north, set North-Up function. (Refer to [DISPLAY DIRECTION])
Automatic Course Up function is not available.	Setting method is wrong.	After setting Automatic Course Up function is set, press [COURSE UP] key. (Refer to [DISPLAY DIRECTION])
Waypoint navigation cannot be set.	Latitude/longitude of own boat are not indicated.	Set after latitude/longitude are indicated.
	Waypoint is not set.	Set the waypoint. (Refer to [ADVANCE WAYPOINT / RETURN WAYPOINT])
Route navigation cannot be set.	Latitude/longitude of own boat are not indicated.	Set after latitude/longitude are indicated.
	Route is not set.	Set the route. (Refer to [SAVE (ERASE) ROUTE])

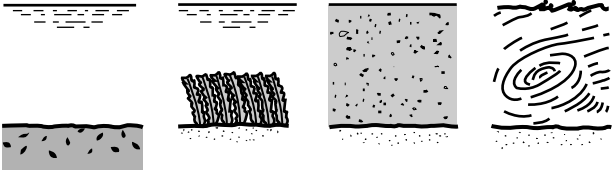
Symptom	Cause	Remedy
Bottom or fish cannot be displayed at all.	Contact problem with transducer connector.	Retighten the connection. Remove/clean the rust/dust. Replace it in the case of corrosion. · Exchange transducer. · Send it for repair.
	<Problem with Transducer> Check followings and replace it in the case of actual problems. 1. It's normal if you hear the sound like "Bo Bo" from the surface of transducer. 2. It's normal if rain like dots appears on the transducer surface after setting the sensitivity and depth to the max and rubbing the transducer surface.	
	Transducer is not immersed enough into the water.	Adjust the transducer installation so that it is always beneath water surface.
	Internal liquid is not enough inside the case.	Add enough liquid to immerse the transducer.
Image does not appear sometimes.	Transducer is not immersed enough into the water.	Adjust the transducer installation so that it is always beneath water surface.
	Problem with the transducer installation causes the image problem due to air bubbles at speeding the vessel.	Check the installation of transducer.
	Influence from other vessel causing air bubbles.	Move to other location or wait until air bubble disappears.
Bottom or fish school is not displayed well.	Too low sensitivity.	Increase the sensitivity. Or, set to auto gain (auto sensitivity control).
	Rubbish and weed attached on the transducer surface. Dirty bottom or liquid.	Remove the excrescence. Remove the dirt from bottom and exchange the liquid.
	Water and environmental conditions may cause the problem with image which is not problem at all.	
		
Too high clutter.	Activate low reflection color. Refer to [CLUTTER]	

Symptom	Cause	Remedy
Too much noise.	Too high sensitivity.	Lower the sensitivity. Set to auto gain (auto gain control)
	Interference with other vessel's echo sounder.	Noise disappears after other vessel moves far away.
	Noise from engine.	Change the routing of cables such as transducer and power cables. (keep distance from the engine as far as possible.)

SPECIFICATIONS

Display	Display	12.1" TFT Color LCD
	Display Style	Landscape
	Number of Pixel	800 × 600
	Operating Voltage	DC11V~30V
	Dimension of Main	242(H)×358(W)×146(D)
	Weight of Main Unit	Approx. 3.7kg
Echo Sounder	Frequency (kHz)	CHIRP 38-70kHz / 130-220kHz TRADITIONAL(depends on transducer)
	Output Power (W)	1kW / 2kW / 3kW/ 5kW
	Depth Range	0~2000m
	Auto Range	OFF / Range / Shift
	Auto Gain	OFF / Low / High
	A-Mode	OFF / ON
	Fish Alarm	OFF / S / L
	Water Temp Alarm	OFF / In Range / Out of Range
	Depth Alarm	OFF / In Range / Out of Range
	Expansion Mode	OFF / Bottom Lock / Automatic Expansion / Manual
	Expansion Rate	× 2 / × 4 / × 8
	Sweep Speed	8 levels (OFF , 1 , 2 , 3 , 4 , S , x2 , x3)
	Background Color	4 Colors (Black, Blue, White, Dark Blue)
	Color Configuration	8 Patterns
	Depth Unit	Meter / Feet / Fathom / Brazas
	Scale Line	OFF/ON
	Super Range	OFF/ON
	STC	OFF / L / M / H
Output Power	OFF / LOW / HIGH	
Pulse Length	S / STD / L	



OVERSEAS SALES DIVISION

20 Oyamazuka, Oiwa-cho, Toyohashi, Aichi 441-3193, Japan

Tel: +81-532-41-2512

<https://www.honda-el.co.jp/en/marine/>

JUN 2025 2nd Edition